

Technical Information & Training Document

# INTRODUCTION OF TUNING FORK QUARTZ CRYSTALS



Prepared by Mario Bruech / QA/QE

## 1. TUNING FORK QUARTZ CRYSTAL INTRODUCTION

- Tuning fork crystals, or also known as wrist watch crystals, are one of the oldest crystal design used for time control in watches, clocks and nowadays in computers and other electronic equipment as Real Time Clock (RTC).
- These crystal units are being manufactured today in mass production in various package sizes and shapes. As everywhere in the industry did miniaturization also affect this crystal type which lead into smaller packages and SMD forms capable for SMT processing.
- The most common frequency used for this purpose is 32.758kHz with which the oscillator can provide a output signal with a one second period time, when the frequency was divided by  $2^{15}$  resulting into a 1Hz (Hertz) signal.
- Frequencies in the range of 30~200kHz are used for other applications.



## 2. QUARTZ CRYSTAL MATERIAL AND WORKING PRINCIPLE

- Quartz crystals, as the name already says, being made out of Quartz. Quartz is a natural material which can be found everywhere on earth, mainly as quartz sand and in rocks formed to crystals. Today quartz is synthetically grown in autoclaves which provides better purity than natural quartz. For tuning fork crystals being Y-bars used, the Y refers to axis of the quartz lattice along which this bar is grown.
- Quartz is being used because of its property to transform mechanical stress into electricity and vice versa. This effect is known as piezo-electrical effect. There are also other materials that can be used as a vibrator utilizing the piezo effect such as ceramics, but among all of them does quartz has the best properties for a vibrating resonator and provides a high Q-factor.
- There are different types of quartz available based on orientation of the atomic space lattice and its orientation. This is differentiated in the names as Left-handed and Right-handed quartz or also called  $\alpha$  and  $\beta$  modification. Both can exist at same time in same quartz block or wafer and both would work at same time. However, this is not a wanted operation mode and needs to be avoided.



### 3. QUARTZ CRYSTAL VIBRATION MODE

- The piezo-electrical effect in quartz can be utilized in different vibration modes based the way these vibrating plates (called crystal wafers or blanks) are being cut out of the raw material in regards of their orientation to the atomic lattice. Below are the most common vibration modes introduced.

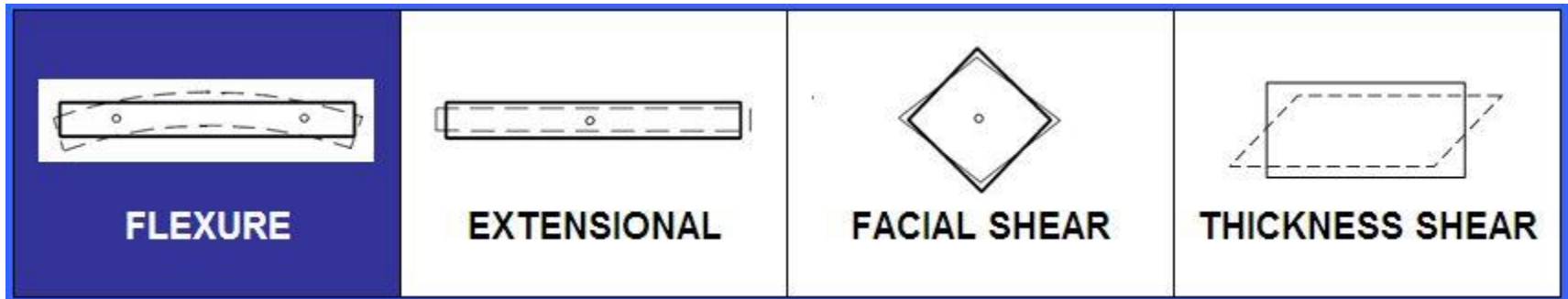

- For tuning fork quartz crystal is the FLEXURE MODE utilized. Flexure mode crystal units are operating mainly in low frequency range below 1MHz. For these crystals is commonly only the FUNDAMENTAL mode used, overtones modes are possible but being not easy to be realized due the high resistance these crystals have in overtone mode.

(The other vibration modes being used as well for other types of crystal units, you may refer to commonly available literature for more information.)

## 4. QUARTZ CRYSTAL CUT

- In order to utilize the desired vibration mode and have the piezo effect working the crystal plates for the resonator need to be cut in a certain angle out of the quartz lattice.
- Over the years were acronyms assigned to these cuts in order to define them properly. For tuning fork crystals, working in flexure mode, being used the so called X-cut, XY-cut or NT-cut.
- The differences among them is related to the properties of the final crystal unit and to the manufacturing technology. The most common one is the X-cut (also called X+2-cut) which is also used on our crystals in cylindrical packages.

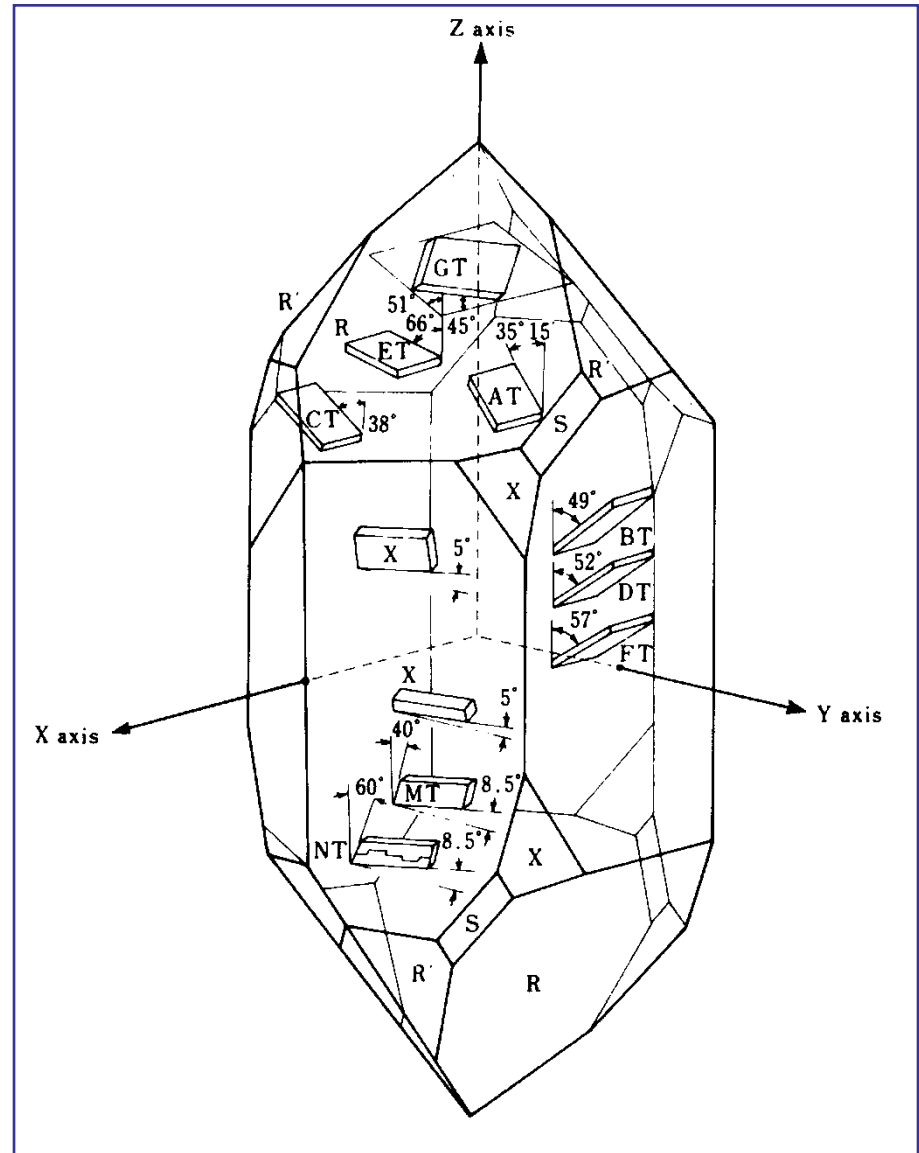

## 5. TUNING FORK FLEXURE MODE OPERATING PRINCIPLE

- The name Tuning Fork comes from the design of the crystal plate (called crystal wafer or blank) being similar to the shape of a tuning fork.
- The working principle is the same as of a tuning fork, the two tips will vibrate with a certain frequency. The frequency is defined by the mass of the tips and this related to the mechanical dimensioning of the tuning fork tips which includes all three dimensions, the length, the width and the height as well.

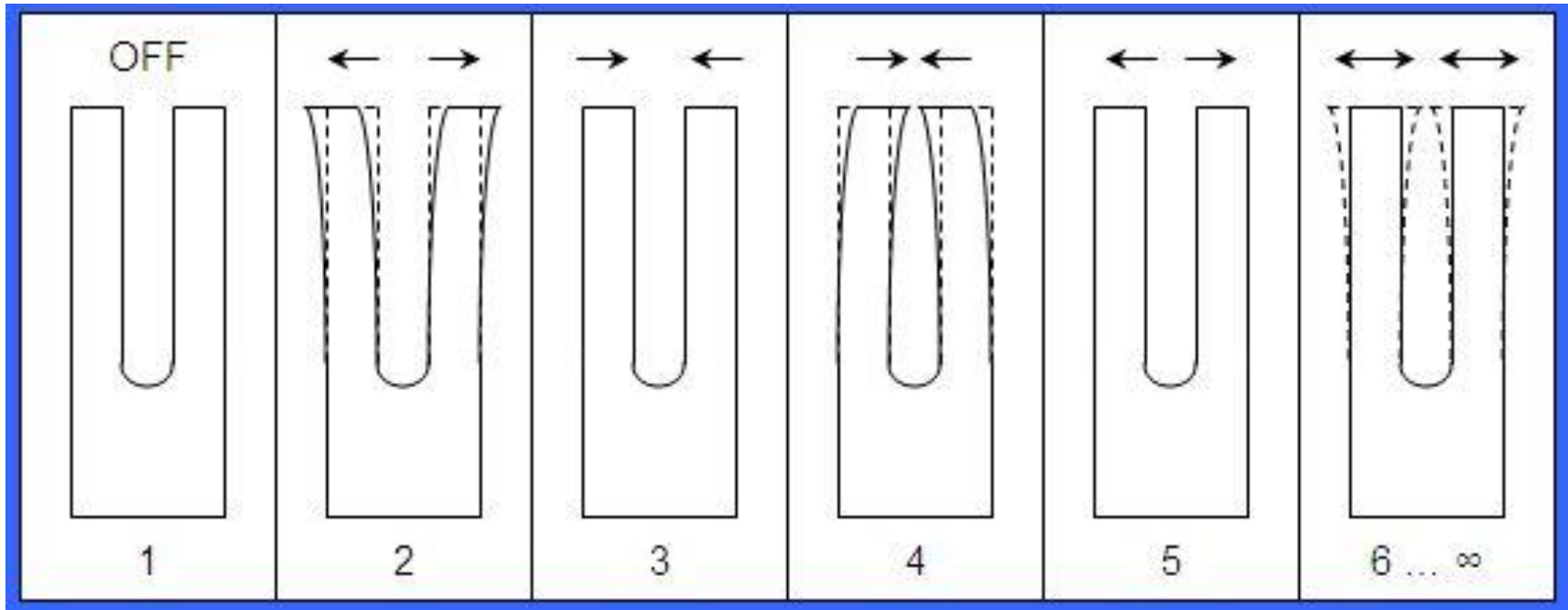

## 6. TUNING FORK FLEXURE MODE ELECTRODE PLATING

- In order to make the mechanical movement of the fork tip working an electrical field needs to be applied to the tuning fork tips. This is being done by plating electrodes onto the surface of the quartz. For these electrodes is mainly silver used but also aluminum and gold are possible.
- The electrode plating onto a tuning fork X-cut crystal needs to be plated on all four sides of the tip and both tips need to have opposite polarity so that the tips will move the way it was described on previous page.

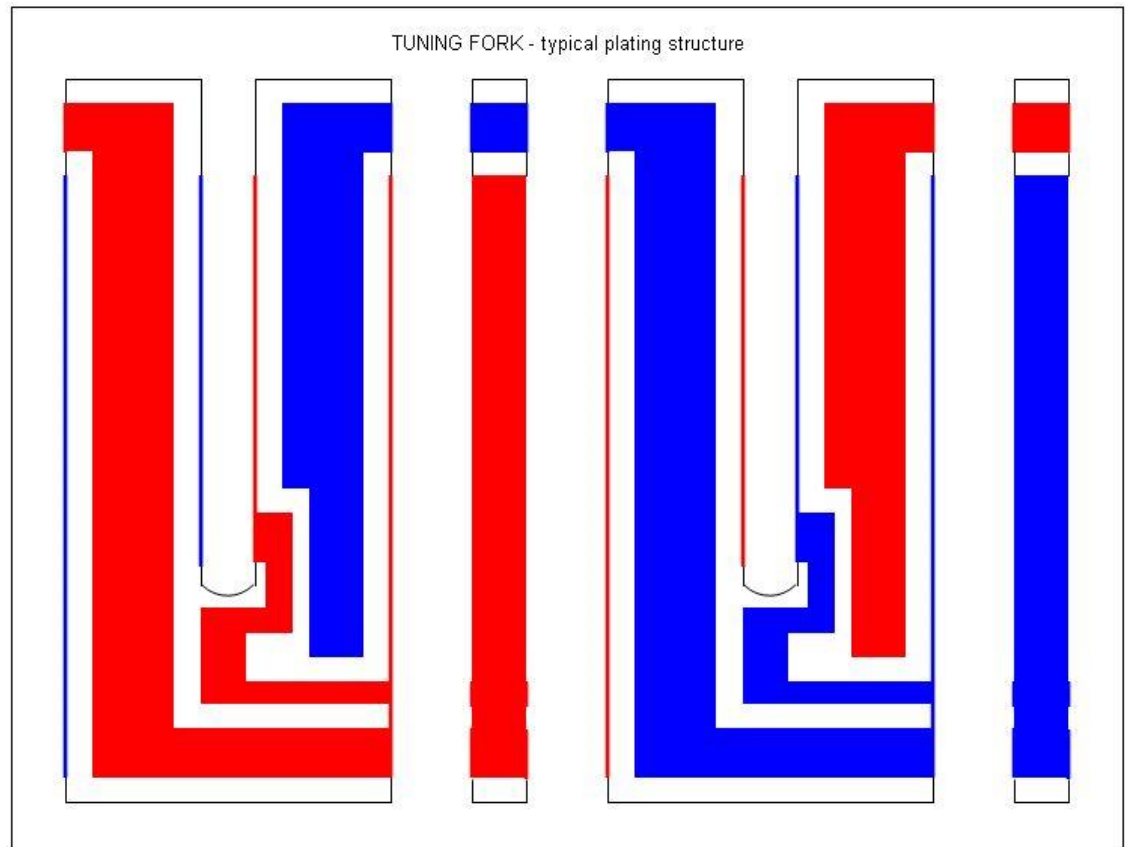
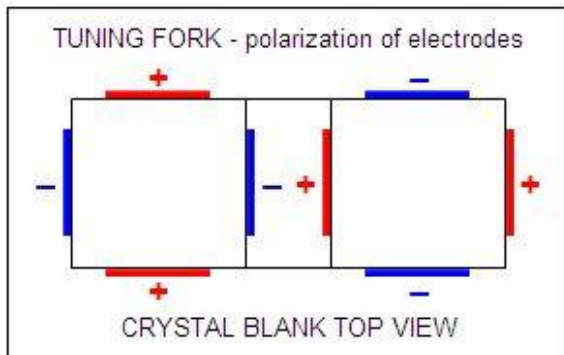

## 7. TUNING FORK CRYSTAL ASSEMBLY

- Shown is a typical tuning fork crystal assembly in cylindrical package type.

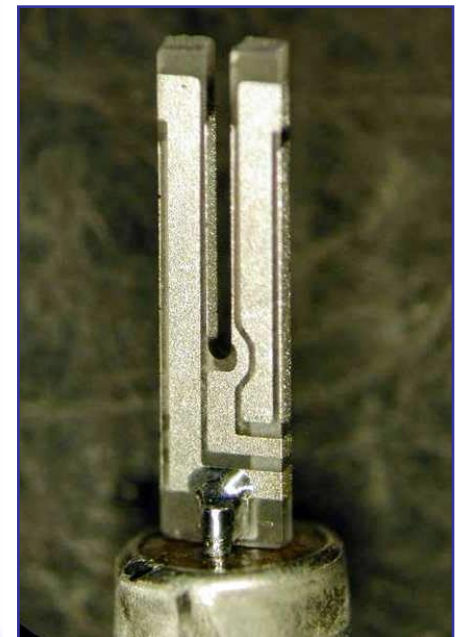
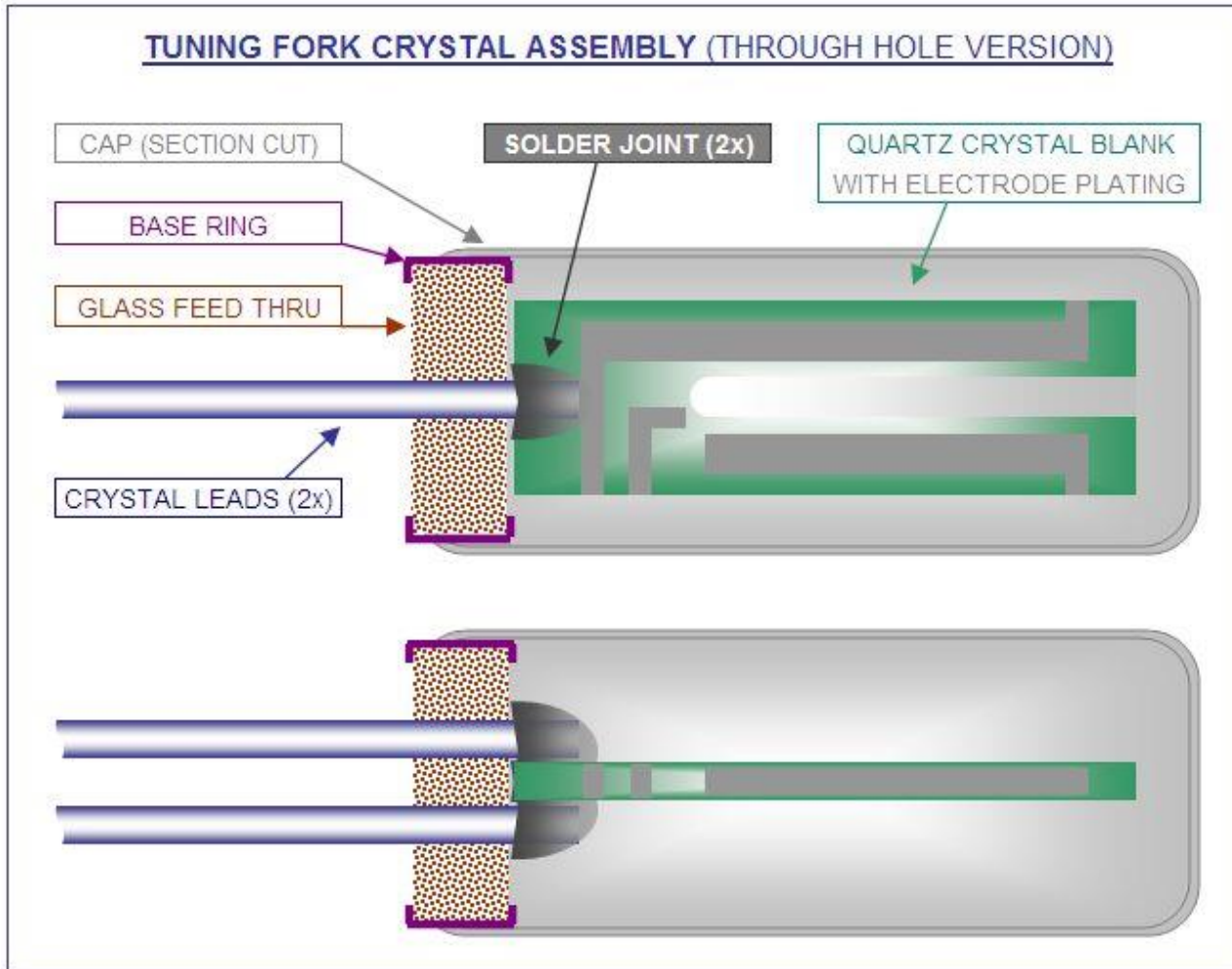

File: RT-DWG-XtalAssyPxxx

SECTION CUT THRU Pxxx CRYSTAL UNIT - THROUGH HOLE

[NO SCALE]



## 8. TUNING FORK CRYSTAL ELECTRICAL PARAMETERS

- The electrical parameters of a quartz crystal depending on its properties based on the quartz cut used. The main parameters can be explained by the equivalent electrical circuit that is abstracted from a mechanical vibration model.
- The mechanical vibration model and its electrical equivalent circuit.
- The electrical equivalent circuit of a quartz crystal unit consists of a series branch of a capacitor C1, an inductor L1 and a resistor R1 in parallel to the shunt capacitance C0.
- Bottom corner shows the symbol of a crystal unit with the external load capacitor CL.

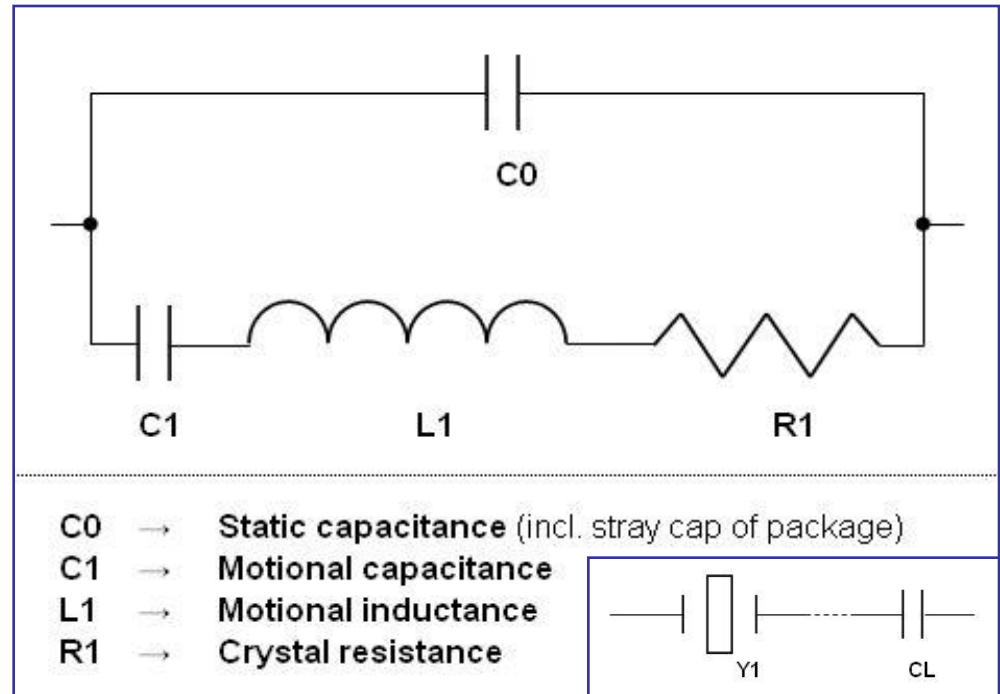
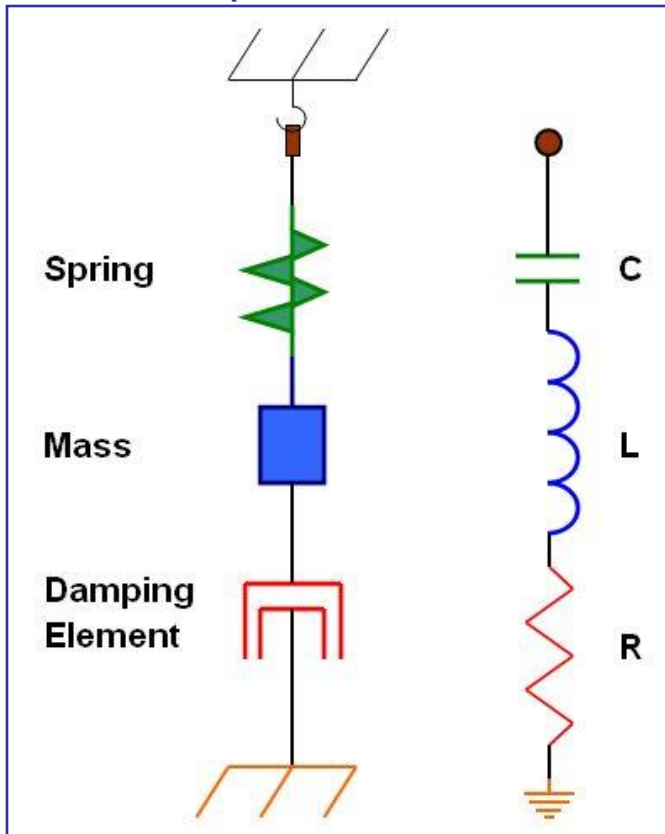

## 8. TUNING FORK CRYSTAL ELECTRICAL PARAMETERS (continued)

- The electrical parameters of a typical Tuning Fork Crystal Unit which customer need to specify are listed in the following table.

PARAMETER	UNIT	TYPICAL VALUE / REMARKS
Package type	-----	Typical package sizes are 3x8mm (R38); 2x6mm (R26) and 1.4x5mm (R145)
Nominal frequency [ $f_N$ ]	kHz	Typical 32.768kHz, other frequencies from 30kHz to 200kHz are available
Frequency tolerance [ $\Delta f/f$ ] (@+25°C)	ppm	Typical $\pm 100$ ppm; $\pm 50$ ppm or $\pm 30$ ppm; tighter tolerance upon request
Load capacitance [CL]	pF	Typical 12.5pF or 6pF, other values between 6 and 30pF are possible (see paragraph 9 for info)
Equivalent Series Resistance [ESR] <sup>1)</sup>	k $\Omega$	Typical 100k $\Omega$ ; 50k $\Omega$ and 30k $\Omega$ MAX; Can vary depending on frequency
Drive Level [DL]	$\mu$ W	Typically 1 $\mu$ W; this parameter depends on customers oscillator design
Aging	ppm/ year	Typically 5ppm MAX per year; other definitions upon request (see page 11 for more info)

1) Equivalent Series Resistance is the resistance that the crystal exhibits when being in the oscillator circuit.

## 8. TUNING FORK CRYSTAL ELECTRICAL PARAMETERS (continued)

- The electrical parameters of a typical Tuning Fork Crystal Unit which customer need to specify are listed in the following table.

PARAMETER	UNIT	TYPICAL VALUE / REMARKS
Shunt capacitance [C0]	pF	Typically ranging from 1.8~4pF depending on frequency and package type (size)
Storage Temperature range [T <sub>STORE</sub> ]	°C	Typically -40 to +85°C
Operating Temperature Range [T <sub>OP</sub> ]	°C	Typically -10 ~ +60°C; -20 ~ +70°C or -40 to +85°C (see next page for more info)
Turnover point temperature range [T <sub>TP</sub> ]	°C	Typically +25 ±5°C (see next page for more info)
Temperature coefficient or also called parabolic curvature constant [k]	ppm/°C <sup>2</sup>	Typically 0.034ppm/°C <sup>2</sup> or 0.035ppm/°C <sup>2</sup> (see next page for more info)

- Additional parameters such as Motional capacitance C1, Capacitance ratio C0/C1, Q factor and other can be specified but being for common applications not necessary. All these parameter vary also depending on frequency and package type, contact manufacturer for more details.

## 8. TUNING FORK CRYSTAL ELECTRICAL PARAMETERS (continued)

- The chart shows the typical Frequency VS Temperature behavior of a Tuning Fork Crystal Unit.
- The green color curve shows the ideal crystal with a curvature constant  $k=0.034\text{ppm}/^\circ\text{C}^2$ , having its turning point exactly at  $+25^\circ\text{C}$  and being set to center frequency at room temperature (0ppm).
- The gray area indicates the range in which a crystal unit could be if manufactured for  $\pm 20\text{ppm}$  tolerance at room temperature (dashed red line), having turning point range  $\pm 25^\circ\text{C}$  and a curvature constant of  $0.034\text{ppm}/^\circ\text{C}^2$ .

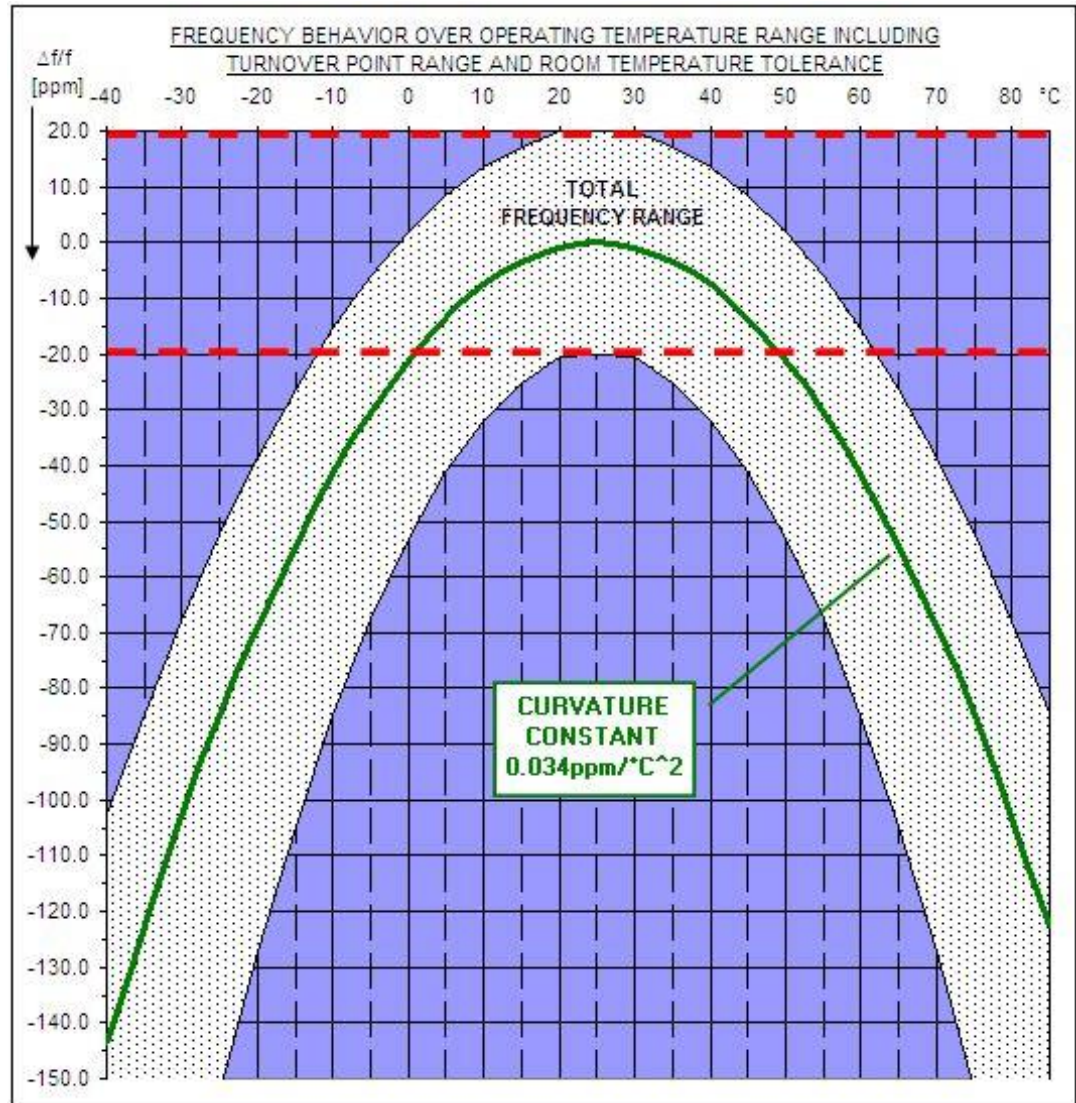

## 8. TUNING FORK CRYSTAL ELECTRICAL PARAMETERS (continued)

■ The chart shows typical aging characteristics of Quartz Crystal Units. The aging depends on various factors and in the sum of those can the frequency increase or decrease. Over time is a quartz crystal stabilizing out as the curves indicate, manufacturers perform a pre-aging during the processing to take the first more progressive portion of the aging out.

- Factors that affect the behavior are:
- Stress
  - Impurities
  - Temperature
  - Manufacturing aspects

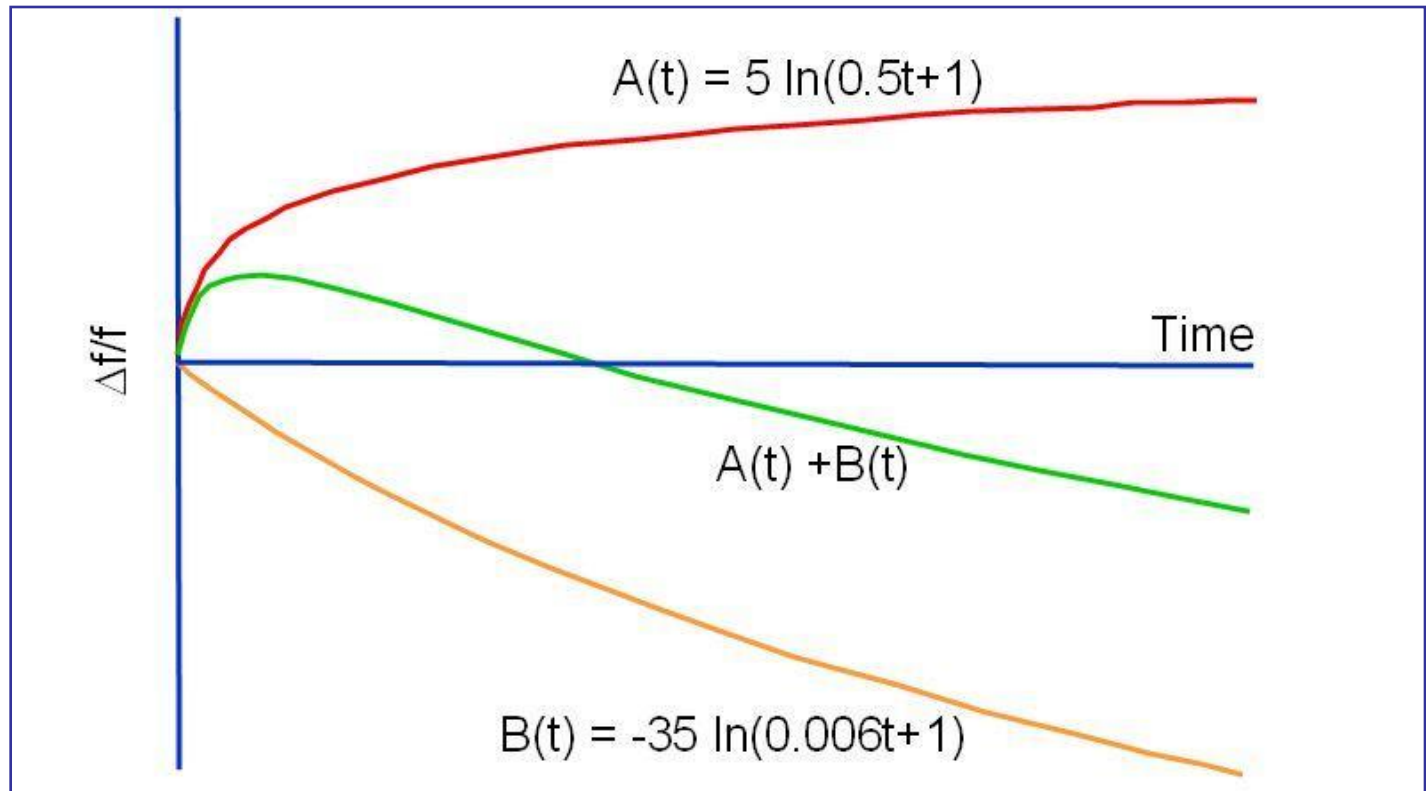

## 9. TUNING FORK CRYSTAL OSCILLATOR CIRCUIT

- Today oscillator circuits are commonly integrated into IC's so that externally are only a few more component needed.
- Schematics on the right shows a typical circuit of a low frequency oscillator. It consists of:
  - An integrated amplifier or gate.
  - The phase shift resistor "Rd", commonly integrated, typical value for 32kHz is 300kΩ.
  - The IC input / output capacitances "CXC\_" shown here for completeness because they are part of the total load capacitance of the circuit.
  - The feedback resistor "Rf", usually external due to his high value of typical 10MΩ.
  - The crystal unit "Y1".
  - The external load capacitors "C1" and "C2", their value depending on circuit design, additional stray capacitance on board and the crystal is being adjusted for.

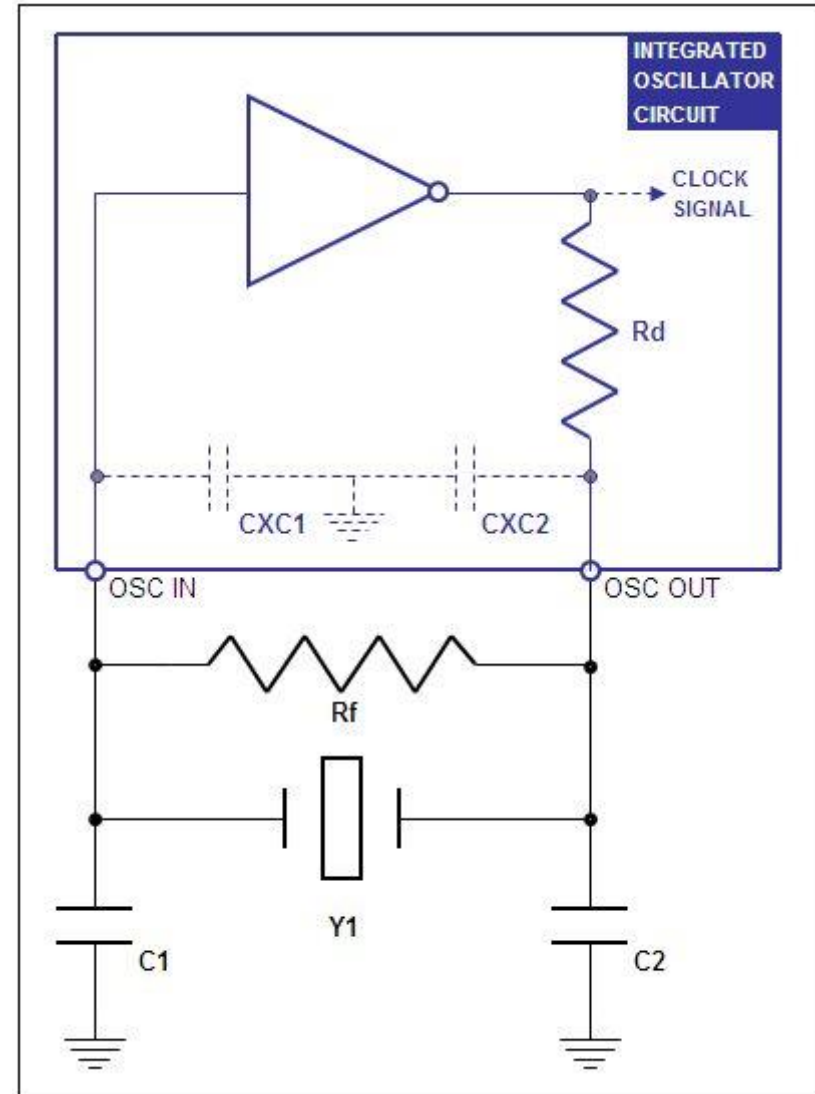

## 10. TUNING FORK CRYSTAL SPECIFICATION

PRODUCT FAMILY (refer to www.nkg.com.hk)	<input type="checkbox"/> 01-CR3-1B <input type="checkbox"/> 01-CR3-2B	<input type="checkbox"/> 01-CR3-05 <input type="checkbox"/> 01-CR3-06	<input type="checkbox"/> 01-CR3-07 <input type="checkbox"/> 01-CR3-09	<input type="checkbox"/> 01-CR3-14 <input type="checkbox"/> 01-CR3-25	<input type="checkbox"/> Other:
NOMINAL FREQUENCY [ $f_N$ ]	<input type="checkbox"/> 32.768		<input type="checkbox"/> Other:		kHz
FREQUENCY TOLERANCE [ $\Delta f/f$ ] (@+25°C)	<input type="checkbox"/> $\pm 50$	<input type="checkbox"/> $\pm 30$	<input type="checkbox"/> $\pm 20$	<input type="checkbox"/> Other:	ppm
LOAD CAPACITANCE [CL]	<input type="checkbox"/> 12.5	<input type="checkbox"/> 9.0	<input type="checkbox"/> 6.0	<input type="checkbox"/> Other:	pF
EQUIVALENT SERIES RESISTANCE [ESR]	<input type="checkbox"/> 100	<input type="checkbox"/> 50	<input type="checkbox"/> 30	<input type="checkbox"/> Other:	k $\Omega$ MAX
DRIVE LEVEL [DL]	<input type="checkbox"/> 1	<input type="checkbox"/> 0.5	<input type="checkbox"/> 0.1	Other:	$\mu$ W TYP
AGING	<input type="checkbox"/> $\pm 5$	<input type="checkbox"/> $\pm 3$		<input type="checkbox"/> Other:	ppm / Y
SHUNT CAPACITANCE (C0)	<input type="checkbox"/> 5pF MAX	<input type="checkbox"/> 3pF MAX	<input type="checkbox"/> TYP:	<input type="checkbox"/> Other:	pF
OPERATING TEMPERATURE RANGE [ $T_{OP}$ ]	<input type="checkbox"/> -10~60	<input type="checkbox"/> -20~70	<input type="checkbox"/> -40~85	<input type="checkbox"/> Other:	°C
TURNOVER POINT TEMPERATURE [ $T_{TP}$ ]	<input type="checkbox"/> +25 $\pm 5$	<input type="checkbox"/> +25 $\pm 10$	<input type="checkbox"/> Other:		°C
TEMPERATURE COEFFICIENT [k]	<input type="checkbox"/> 0.034	<input type="checkbox"/> 0.04	<input type="checkbox"/> Other:		ppm/°C <sup>2</sup>
STORAGE TEMPERATURE RANGE [ $T_{STORE}$ ]	<input type="checkbox"/> -40~85		<input type="checkbox"/> Other:		°C
PACKAGING INSTRUCTIONS:	<input type="checkbox"/> BULK	<input type="checkbox"/> T&R	<input type="checkbox"/> Other:		
ADDITIONAL SPECIFICATION DETAILS:					
WHAT IS YOUR PROJECTED USAGE?	<input type="checkbox"/> pcs / MONTH	<input type="checkbox"/> pcs / YEAR			
SAMPLE QTY / ELECTRICAL DATA REQUEST	<input type="checkbox"/> 10pcs	<input type="checkbox"/> 20pcs	<input type="checkbox"/> 50pcs	<input type="checkbox"/> Other:	<input type="checkbox"/> Data

# THANK YOU FOR YOUR ATTENTION.

For further information you may look at our web page  
[www.nkg.com.hk](http://www.nkg.com.hk)  
or you contact us per E-mail at [info@nkg.com.hk](mailto:info@nkg.com.hk) or our contact form on  
the web page  
Our address, phone and fax you can find on the web page under contact.

## END